

SAM

External Mix/Flat Fan or Narrow Round

DESIGN FEATURES

- Separate atomizing and fan air lines provide variable coverage and fine control of drop size without affecting liquid flow rates. Higher atomizing air pressure yields finer drop size; higher fan air pressure yields broader patterns
- Pneumatically controlled shut-off and clean-out built in
- External mix; allows spraying of viscous materials
- Liquid flow rates are independent of air
- Precise metering of the liquid flow rate

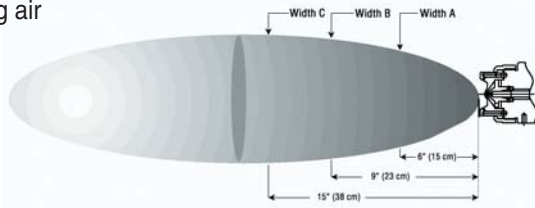

SAM Liquid Flow Rates

Pipe Size	Spray Set-Up No.	Fluid Cap and Air Cap No.	Liquid Capacity l/h @ bar					
			0.2 bar	0.3 bar	0.5 bar	0.7 bar	1 bar	1.5 bar
1/8"	SAM-01-02	FCS 01 & ACS 02	2.7	3.3	4.3	5.1	6.2	7.6
	SAM-02-02	FCS 02 & ACS 02	4.5	5.5	7.2	8.5	10.2	12.5
	SAM-03-02	FCS 03 & ACS 02	8.8	10.8	14.0	16.6	19.9	24
	SAM-04-03	FCS 04 & ACS 03	13.5	16.5	21	25	30	37
	SAM-05-03	FCS 05 & ACS 03	17.2	21	27	32	38	46
	SAM-06-04	FCS 06 & ACS 04	37	46	60	72	86	107
	SAM-07-05	FCS 07 & ACS 05	59	74	97	116	140	174

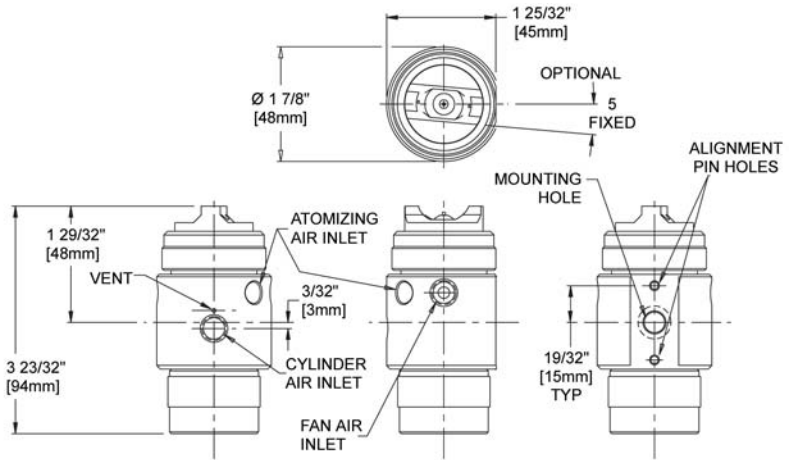

SAM Air Flow Rates

Pipe Size	Spray Set-Up No.	Fluid Cap and Air Cap No.	Atomizing Air Capacity Nm ³ /h @ bar								
			0.7 bar	1 bar	1.5 bar	2 bar	2.5 bar	3 bar	4 bar	5 bar	6 bar
1/8"	SAM-01-02	FCS 01 & ACS 02	0.8	1.0	1.3	1.6	1.9	2.2	2.8	3.3	3.9
	SAM-02-02	FCS 02 & ACS 02									
	SAM-03-02	FCS 03 & ACS 02									
	SAM-04-03	FCS 04 & ACS 03	2.8	3.3	4.1	5.0	5.8	6.7	8.3	10.0	11.7
	SAM-05-03	FCS 05 & ACS 03	3.5	4.1	5.1	6.2	7.2	8.2	10.2	12.3	14.3
	SAM-06-04	FCS 06 & ACS 04									
	SAM-07-05	FCS 07 & ACS 05	4.5	5.3	6.7	8.0	9.3	10.6	13.3	15.9	18.5

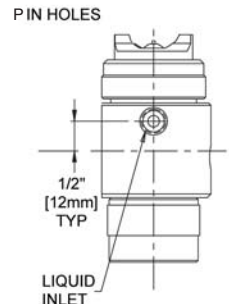

Pipe Size	Spray Set-Up No.	Fluid Cap and Air Cap No.	Fan Air Capacity Nm ³ /h @ bar								
			0.7 bar	1 bar	1.5 bar	2 bar	2.5 bar	3 bar	4 bar	5 bar	6 bar
1/8"	SAM-01-02	FCS 01 & ACS 02	2.7	3.2	4.1	4.9	5.8	6.6	8.3	10.0	11.8
	SAM-02-02	FCS 02 & ACS 02									
	SAM-03-02	FCS 03 & ACS 02									
	SAM-04-03	FCS 04 & ACS 03	5.0	6.1	7.8	9.6	11.3	13.1	16.6	20	24
	SAM-05-03	FCS 05 & ACS 03	5.7	6.9	9.0	11.2	13.3	15.4	19.6	24	28
	SAM-06-04	FCS 06 & ACS 04									
	SAM-07-05	FCS 07 & ACS 05	5.9	7.2	9.3	11.4	13.6	15.7	20.0	24	29

Standard Materials: 303 Stainless Steel, Blue-gard® gasket, Viton® o-rings

Note: Spray set-ups consist of fluid and air caps. Set-ups are interchangeable but each uses a different needle size.

Air-Operated Clean-out/Shut-off. Removal of air pressure to the cylinder causes a spring-loaded poppet valve actuator to shut off liquid flow and includes a clean-out needle.

Replacement air caps include replacement Blue-Gard® gaskets.

Spray angle performance varies with pressure. Contact BETE for specific data on critical applications.

Dimensions are approximate. Check with BETE for critical dimension applications.

SAM Coverage Chart

Variable Spray, Pressure Fed, Flat Fan or *Narrow Round Spray Pattern

Pipe Size	Spray Set-up No.	Fluid Cap and Air Cap No.	Spray Dimensions with Varied Fan Air Pressure													
			bar air	bar liquid	0* bar			0.7 bar			2.5 bar			4 bar		
					A (mm)	B (mm)	C (mm)	A (mm)	B (mm)	C (mm)	A (mm)	B (mm)	C (mm)	A (mm)	B (mm)	C (mm)
1/8	SAM-01-02	FCS 01 & ACS 02	0.7	0.2	50	80	100	180	230	250	150	200	280	150	200	280
				0.7	60	90	110	180	250	300	180	200	280	180	200	300
				1.5	50	80	100	200	300	360	230	280	360	200	250	330
			2	0.2	50	80	110	130	150	180	200	250	360	200	280	360
				0.7	50	60	130	150	180	250	200	250	330	200	250	300
				1.5	50	80	100	180	230	330	250	300	380	240	290	370
		2.5	0.2	60	90	150	130	150	200	200	250	360	230	280	360	
			0.7	50	80	130	150	180	250	230	280	360	230	280	330	
			1.5	50	80	110	180	200	300	250	300	360	250	300	380	
		4	0.2	60	90	150	100	130	150	200	280	330	230	280	360	
			0.7	50	80	130	110	130	180	200	250	360	230	300	380	
			1.5	50	80	110	130	180	230	230	300	410	250	330	430	
	SAM-02-02	FCS 02 & ACS 02	0.7	0.2	50	80	100	200	250	300	160	220	280	150	230	300
				0.7	60	90	110	200	300	380	230	360	460	180	250	330
				1.5	50	80	100	200	300	380	200	360	460	200	250	330
			2	0.2	50	80	110	140	180	200	250	300	360	200	280	360
				0.7	50	80	130	180	230	300	250	300	360	230	250	330
				1.5	50	80	100	180	250	300	330	410	460	240	290	370
		2.5	0.2	60	90	150	130	180	230	200	250	360	230	280	360	
			0.7	50	80	130	180	200	160	240	300	360	230	300	380	
			1.5	50	80	110	160	230	320	290	380	430	280	360	460	
		4	0.2	60	90	150	110	140	180	200	270	330	230	280	360	
			0.7	60	100	140	130	150	220	230	280	360	250	300	380	
			1.5	50	80	110	140	190	240	250	360	460	280	360	460	
SAM-03-02	FCS 03 & ACS 02	0.7	0.2	50	80	130	230	300	380	180	230	280	180	230	300	
			0.7	50	60	100	300	380	530	300	510	580				
			1.5	50	80	100	250	300	410							
		2	0.2	60	80	110	150	200	230	200	250	330	200	250	330	
			0.7	50	80	130	200	280	380	280	330	330	250	280	330	
			1.5	50	60	100	200	300	360	410	510	560				
	2.5	0.2	60	90	130	130	180	250	200	250	330	200	280	330		
		0.7	50	80	130	180	200	280	280	330	380	250	300	330		
		1.5	50	80	130	180	230	370	330	460	530	300	430	530		
	4	0.2	60	90	140	130	150	200	200	250	330	200	250	330		
		0.7	60	90	140	150	180	240	250	330	410	280	330	380		
		1.5	50	80	110	150	200	250	300	460	560	330	460	530		
SAM-04-03	FCS 04 & ACS 03	0.7	0.2	60	90	130	230	330	480							
			0.7	50	80	110	150	360	410	460	610	740				
			1.5	60	90	130	230	330	480							
		2	0.2	60	80	130	100	130	180	280	380	460	300	380	460	
			0.7	60	90	130	130	180	230	330	430	560	200	530	660	
			1.5	60	90	140	130	150	230	330	510	610	180	560	690	
	2.5	0.2	60	80	130	90	110	160	230	300	360	280	330	460		
		0.7	60	90	130	100	130	180	250	360	460	130	460	560		
		1.5	60	90	130	100	140	200	280	380	530	150	510	630		
	4	0.2	60	90	130	80	100	150	200	250	330	250	300	430		
		0.7	60	90	110	80	100	150	200	280	360	280	380	460		
		1.5	60	90	110	80	110	180	250	300	410	300	430	560		
SAM-05-03	FCS 05 & ACS 03	0.7	0.2	80	100	150	230	300	460							
			0.7				200	280	380	610	740	890				
			1.5				230	300	380	530	710					
		2	0.2	60	90	150	100	150	200	300	380	480	300	380	480	
			0.7	60	90	130	110	150	200	360	460	580	430	560	630	
			1.5	50	80	130	110	150	230	380	480	690	460	580	690	
	2.5	0.2	60	90	150	90	130	180	250	330	430	300	360	460		
		0.7	60	90	140	100	150	200	300	410	510	380	460	560		
		1.5	60	90	140	90	130	230	330	430	560	410	510	610		
	4	0.2	60	90	150	60	100	180	230	280	360	250	300	430		
		0.7	60	90	140	80	100	150	250	330	410	330	410	510		
		1.5	60	90	140	80	100	150	230	330	430	300	430	580		
SAM-06-04	FCS 06 & ACS 04	0.7	0.2	80	100	130	180	250	330	530	660	840				
			0.7				430	560	760	560	690	860				
			1.5													
		2	0.2	80	100	130	100	150	200	300	360	530	380	480	560	
			0.7	60	90	130	100	150	220	330	410	560	410	530	580	
			1.5				280	410	530	460	460	610				
	2.5	0.2	80	100	140	40	130	180	250	300	430	300	430	530		
		0.7	60	90	130	100	130	180	280	360	510	360	460	640		
		1.5	60	90	130	80	130	200	230	330	430	330	460	660		
	4	0.2	80	100	150	80	100	150	200	250	330	250	330	460		
		0.7	80	100	130	90	110	180	230	300	410	300	410	530		
		1.5	80	90	130	80	100	140	200	250	380	300	410	530		
SAM-07-05	FCS 07 & ACS 05	0.7	0.2	80	100	130	200	280	380							
			0.7							530	690	890				
			1.5							480	610	840				
		2	0.2	80	100	130	130	160	230	330	460	580	430	630	690	
			0.7				150	180	250	330	430	560	460	560	740	
			1.5							360	430	610				
	2.5	0.2	80	100	140	140	150	230	280	380	480	430	610	760		
		0.7	80	90	130	110	180	190	300	380	510	410	510	740		
		1.5				300	360	530	360	530	690	360	480	690		
	4	0.2	80	100	150	100	150	200	230	300	410	360	430	530		
		0.7	80	100	160	130	160	190	250	330	430	330	430	580		
		1.5	60	80	130	90	110	150	180	360	380	310	410	610		

Spray angle performance varies with pressure. Contact BETE for specific data on critical applications.